

VERDERAIR VA 8

Air-Operated Diaphragm Pumps

819.6247

Rev. ZAP
EN

For fluid transfer applications. For professional use only.

0.7 MPa, 7 bar Maximum Incoming Air Pressure

0.7 MPa, 7 bar Maximum Fluid Working Pressure



Important Safety Instructions

Read all warnings and instructions in this manual.
Save these instructions.

Patent No.

CN ZL01113998.6

EU 0942171

US 5,860,794

AR AR006617B1

KP 461707

CN ZL01124998.6

BR PI9701779_5

Contents

Warnings	3
Installation	5
Operation.....	9
Maintenance.....	11
Troubleshooting.....	12
Service	14
Parts Listing.....	17
Service Kit Listing.....	17
Parts Lists.....	19
Parts Drawing.....	18
Torque Sequence.....	21
Technical Data	22
Dimensions and Mounting Hole Layout.....	22
Performance Charts	23
Customer/Guarantee.....	25

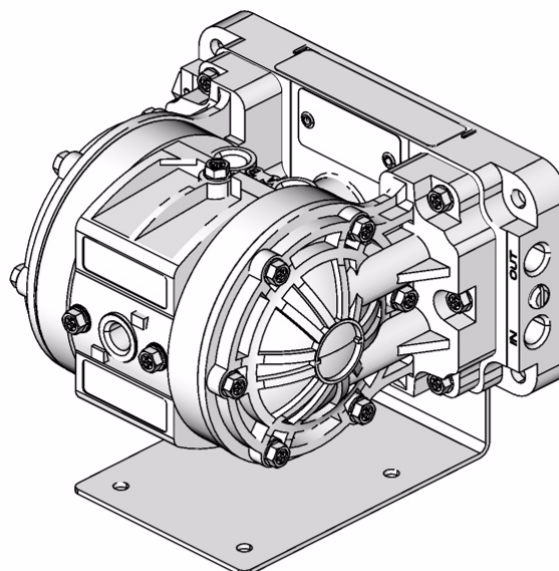

**Model 810.6012
shown**

ti10660a



Configuration Number Matrix

Check the identification plate (ID) for the 15-digit Configuration Number of your pump. Use the following matrix to define the components of your pump.

Sample Configuration Number: VA08PP – PP TF TB 00

VA08	P	P	–	PP	TF	TX	00
Pump Model	Fluid Section	Air Section	–	Checks	Diaphragms	Connections	Options

NOTE: Some combinations are not possible. Please check with your local supplier, or see the pump listing on page 17.

Pump Model (1 and 2)	Fluid Section Material (3)		Air Section Material (4)		Seats (5)	Checks (6)	
VA08	D	Acetal*	P	Polypropylene	– (none)	AC	Acetal
	K	PVDF				KY	PVDF
	P	Polypropylene				PP	Polypropylene

Diaphragm (7)		Connections (8)		Options (9)	
TF	PTFE with fluoroelastomer O-Ring	TX	Threaded NPT/BSPT	00	Standard
SP	Santoprene with fluoroelastomer O-Ring			RE	Remote (Solenoid)



II 2 GD
 Ex h IIC 66°C...135°C Gb
 Ex h IIIC T135°C Db

ATEX T-code rating is dependent on the temperature of the fluid being pumped. Fluid temperature is limited by the materials of the pump interior wetted parts. See "Technical Data" on page 22 for the maximum fluid operating temperature for your specific pump model.

Warnings

Warning Symbol



This symbol alerts you to the possibility of serious injury or death if you do not follow the instructions.

Caution Symbol



This symbol alerts you to the possibility of damage to or destruction of equipment if you do not follow the instructions.

Warning



EQUIPMENT MISUSE HAZARD

Any misuse of the equipment or accessories, such as over-pressurizing, modifying parts, using incompatible chemicals and fluids, or using worn or damaged parts, can cause them to rupture and result in splashing in the eyes or on the skin, other serious injury, or fire, explosion or property damage.

- This equipment is for professional use only. Observe all warnings. Read and understand all instruction manuals, warning labels, and tags before you operate this equipment. If you are not sure, or if you have questions about installation or operation, call your VERDER distributor.
- Never alter or modify any part of this equipment; doing so could cause it to malfunction.
- Check all equipment regularly and repair or replace worn or damaged parts immediately.
- Never exceed the recommended working pressure or the maximum air inlet pressure stated on your pump or in the **Technical Data** on page 22.
- Do not exceed the maximum working pressure of the lowest rated component in your system. This equipment has a **0.7 MPa (7 bar) maximum working pressure at 0.7 MPa (7 bar) maximum incoming air pressure.**
- Be sure that all fluids and solvents used are chemically compatible with the wetted parts shown in the **Technical Data** on page 22. Always read the manufacturer's literature before you use fluid or solvent in the pump.
- Never move or lift a pump under pressure. If dropped, the fluid section may rupture. Always follow the **Pressure Relief Procedure** on page 9 before you move or lift the pump.

Warning



HAZARDOUS FLUIDS

Improper handling of hazardous fluids or inhaling toxic vapors can cause extremely serious injury or death from splashing in the eyes, ingestion, or bodily contamination. Observe all the following precautions when you handle hazardous or potentially hazardous fluids.



- Know what fluid you are pumping and its specific hazards. Take precautions to avoid a toxic fluid spill.
- Always wear appropriate clothing and equipment, such as eye protection and breathing apparatus, to protect yourself.
- Store hazardous fluid in an appropriate, approved container. Dispose of it according to all Local, State, and Federal guidelines for hazardous fluids.
- Secure the fluid outlet hose tightly into the receiving container to prevent it from coming loose and improperly draining the fluid.
- Pipe and dispose of the exhaust air safely, away from people, animals, and food handling areas. If the diaphragm fails, the fluid is exhausted along with the air. See **Air Exhaust Ventilation** on page 5.



FIRE AND EXPLOSION HAZARD

Static electricity is created by the flow of fluid through the pump and hose. If the equipment is not properly grounded, sparking may occur. Sparks can ignite fumes from solvents and the fluid being pumped, dust particles, and other flammable substances, whether you are pumping indoors or outdoors, and can cause a fire or explosion and serious injury and property damage.



- To reduce the risk of static sparking, ground the pump and all other equipment used or located in the work area. Check your local electrical code for detailed grounding instructions for your area and type of equipment. See **Grounding** on page 5.
- If you experience any static sparking or even a slight shock while using this equipment, **stop pumping immediately**. Check the entire system for proper grounding. Do not use the system again until you have identified and corrected the problem.
- Pipe and dispose of the exhaust air safely, away from all sources of ignition. If the diaphragm fails, the fluid is exhausted along with the air. See **Air Exhaust Ventilation** on page 5.
- **Never** use a polypropylene or PVDF pump with non-conductive flammable fluids as specified by your local fire protection code. Refer to **Grounding** on page 5 for additional information. Consult your fluid supplier to determine the conductivity or resistivity of your fluid.
- Provide fresh air ventilation to avoid the buildup of flammable fumes from solvents or the fluid being pumped.
- Do not smoke in the work area. Do not operate the equipment near a source of ignition or an open flame, such as a pilot light.

Comply with all applicable local, state and national fire, electrical and safety regulations.

VERDEAIR Installation

Tightening Threaded Fasteners Before First Use

Before using the pump for the first time, check and retorquer all external fasteners. See **Torque Sequence** on page 21. After the first day of operation, retorquer the fasteners. Although pump use varies, a general guideline is to retorquer fasteners every two months.

Use a compatible thread sealant on all male threads. Tighten all connections firmly to avoid air or fluid leaks.

Caution

To avoid pump damage, do not overtighten the fittings to the pump.

Grounding

Warning



This pump must be grounded. Before you operate the pump, ground the system as explained below. Also read the section **FIRE AND EXPLOSION HAZARD** on page 4.



The *acetal pump* contains stainless steel fibers which make the wetted parts conductive. Attaching the ground wire to one of the grounding locations grounds the wetted parts.

The *polypropylene and PVDF pumps* are **not** conductive. When you pump conductive flammable fluids, **always** ground the entire fluid system. Make sure the fluid has an electrical path to a true earth ground, see FIG. 1. **Never** use a polypropylene or PVDF pump with non-conductive flammable fluids as specified by your local fire protection code.

US Code (NFPA 77 Static Electricity) recommends a conductivity greater than 50×10^{-12} Siemens/meter (mhos/meter) over your operating temperature range to reduce the hazard of fire. Consult your fluid supplier to determine the conductivity or resistivity of your fluid. The resistivity must be less than 2×10^{12} ohm-centimeters.

To reduce the risk of static sparking, ground the pump and all other equipment used or located in the pumping area. Check your local electrical code for detailed grounding instructions for your area and type of equipment.

Acetal Pump Grounding Instructions

For polypropylene and PVDF pumps, see the warning above.

Ground all of this equipment.

Pump: Connect a ground wire (A) and clamp, Part No. 819.0157. See FIG. 1. The pump grounding locations are on the manifold between the inlet and outlet ports. Use the nut (B) and bolt (C) that are provided with the pump, and install as follows:

1. Place the nut in the nut catcher on the underside of the manifold.
2. Insert the bolt through the loop end of the ground wire.
3. Insert the bolt through the hole on the pump manifold and tighten it into the nut that you positioned in step 1.
4. Connect the clamp end of the ground wire to a true earth ground.

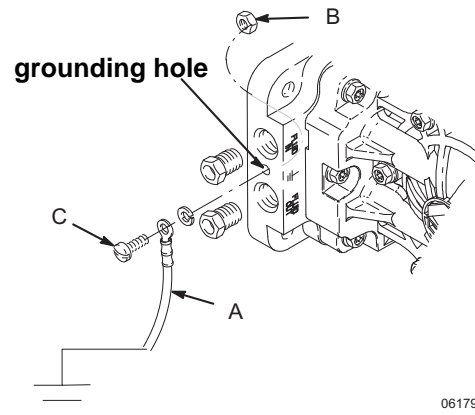

FIG. 1

Air and fluid hoses: Use only grounded hoses with a maximum of 500 ft (150 m) combined hose length to ensure grounding continuity.

Air compressor: Follow the manufacturer's recommendations.

All solvent pails used when flushing: Follow the local code. Use only grounded metal pails, which are conductive. Do not place the pail on a non-conductive surface, such as paper or cardboard, which interrupts the grounding continuity.

Fluid supply container: Follow the local code.

Air Exhaust Ventilation

Warning

TOXIC FLUID HAZARD



Read the **USING HAZARDOUS FLUIDS** and **FIRE AND EXPLOSION HAZARD** sections on page 4 before you operate this pump.



Be sure the system is properly ventilated for your type of installation. You must vent the exhaust to a safe place, away from people, animals or food handling areas when pumping flammable or hazardous fluids



If the diaphragm ruptures, the fluid being pumped is exhausted with the air. Place a container at the end of the air exhaust line to catch fluid in case the diaphragm ruptures, and disconnect the pump.

Installation

Mountings

Caution

The pump exhaust air may contain contaminants. If needed, ventilate to a remote area to reduce possible fluid contamination. See **Air Exhaust Ventilation** on page 5.

- **Mounting Bracket:**

The pump is shipped with a 90 degree mounting bracket (60). Mount the pump to the bracket using the four screws (61) provided. Secure the opposite portion of the mounting bracket to a horizontal surface. The mounting bracket must be used for proper pump performance.

- Be sure the mounting can support the weight of the pump, hoses, and accessories, as well as the stress caused during operation.
- For all mountings, be sure the pump is secured with screws and nuts.
- Do not expose pump or the plastic components to direct sunlight for prolonged periods. Prolonged exposure to UV radiation will degrade natural polypropylene components of the pumps.

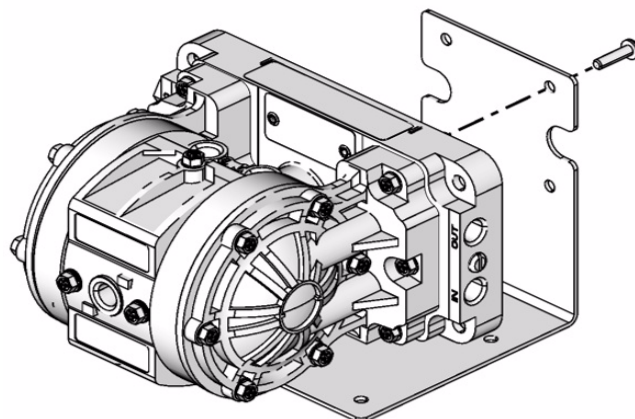

ti10662a

FIG. 2

Warning

To reduce the risk of serious injury, splashing in the eyes or on the skin, and toxic fluid spills, **never** move or lift a pump under pressure. If dropped, the fluid section may rupture. Always follow the **Pressure Relief Procedure** on page 9 before you move or lift the pump.

VERDERAIR

Installation

Air Lines

Warning

Bleed-Type Master Air Valve and Fluid Drain Valve

A bleed-type master air valve and a fluid drain valve are required on your system.

The bleed-type master air valve relieves air trapped between itself and the pump. Trapped air can cause the pump to cycle unexpectedly, which could result in serious bodily injury, including splashing in the eyes, injury from moving parts, or contamination from hazardous fluids.

The fluid drain valve reduces the risk of serious bodily injury, including splashing in the eyes or on the skin, or contamination from hazardous fluids. Install the fluid drain valve close to the pump's fluid outlet to relieve pressure in the hose if the hose becomes plugged.

1. Mount the air line accessories on the wall or on a bracket. Be sure the air line supplying the accessories is grounded.
 - a. The pump speed can be controlled in one of two ways: To control it on the air side, install an air regulator. To control it on the fluid side, install a fluid valve near the outlet.
 - b. Install a bleed-type master air valve downstream from the air regulator, and use it to relieve trapped air. See the **Bleed-Type Master Air Valve and Fluid Drain Valve** warning at left. Locate another bleed-type master air valve upstream from all air line accessories, and use it to isolate the accessories during cleaning and repair.
 - c. The air line filter removes harmful dirt and moisture from the compressed air supply.

2. Install a flexible air hose between the accessories and the pump air inlet. Screw the air line fitting into the air inlet.
3. Do not restrict the exhaust port. Excessive exhaust restriction can cause erratic pump operation.

Fluid Lines

FIG. 3. On each end of the fluid manifold are a fluid IN port and a fluid OUT port. **NOTE: Make sure the fluid OUT port on the fluid manifold is mounted up.** This will insure proper pump priming. **Fluid-in** and **fluid-out** lines can be connected on the same end, or opposite ends of the manifold. Plug ports that are not used (plugs provided).

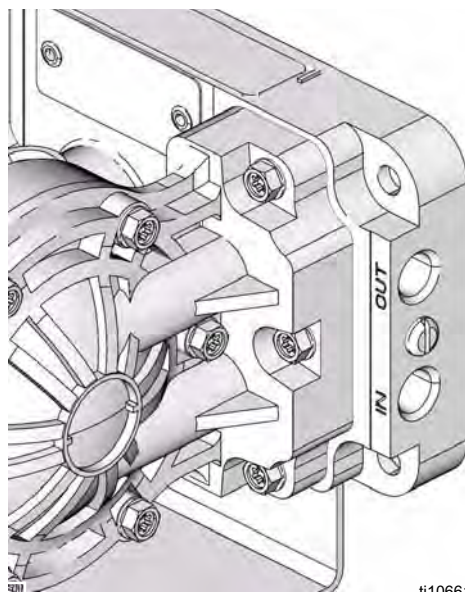

FIG. 3

ti10661a

VERDERAIR

Installation

Typical Installation

The installation shown in FIG. 4 is only a guide to help select and install a pump; they are not actual system designs.

Typical installation includes (not supplied by VERDER):

- For solenoid operation: four-way, 5-port, 2-position solenoid valve with 1/4-in. ports.

KEY

- A VERDERAIR VA 8 pump
- B Bleed-type master air valve (required for pump)
- C Air line(s)
- E Master air valve (for accessories)
- F Air line filter
- G Muffler
- H Pump air regulator
- J Fluid drain valve (required on fluid outlet side of pump)
- L Fluid suction line
- N Fluid supply hose
- T Bung adapter
- U 4-way solenoid
- Y Ground wire (required)

See page 5 for installation instructions.

⚠ Caution

For solenoid operation, the pump must exhaust through the solenoid. Failure to exhaust through solenoid could cause the diaphragms to fail.

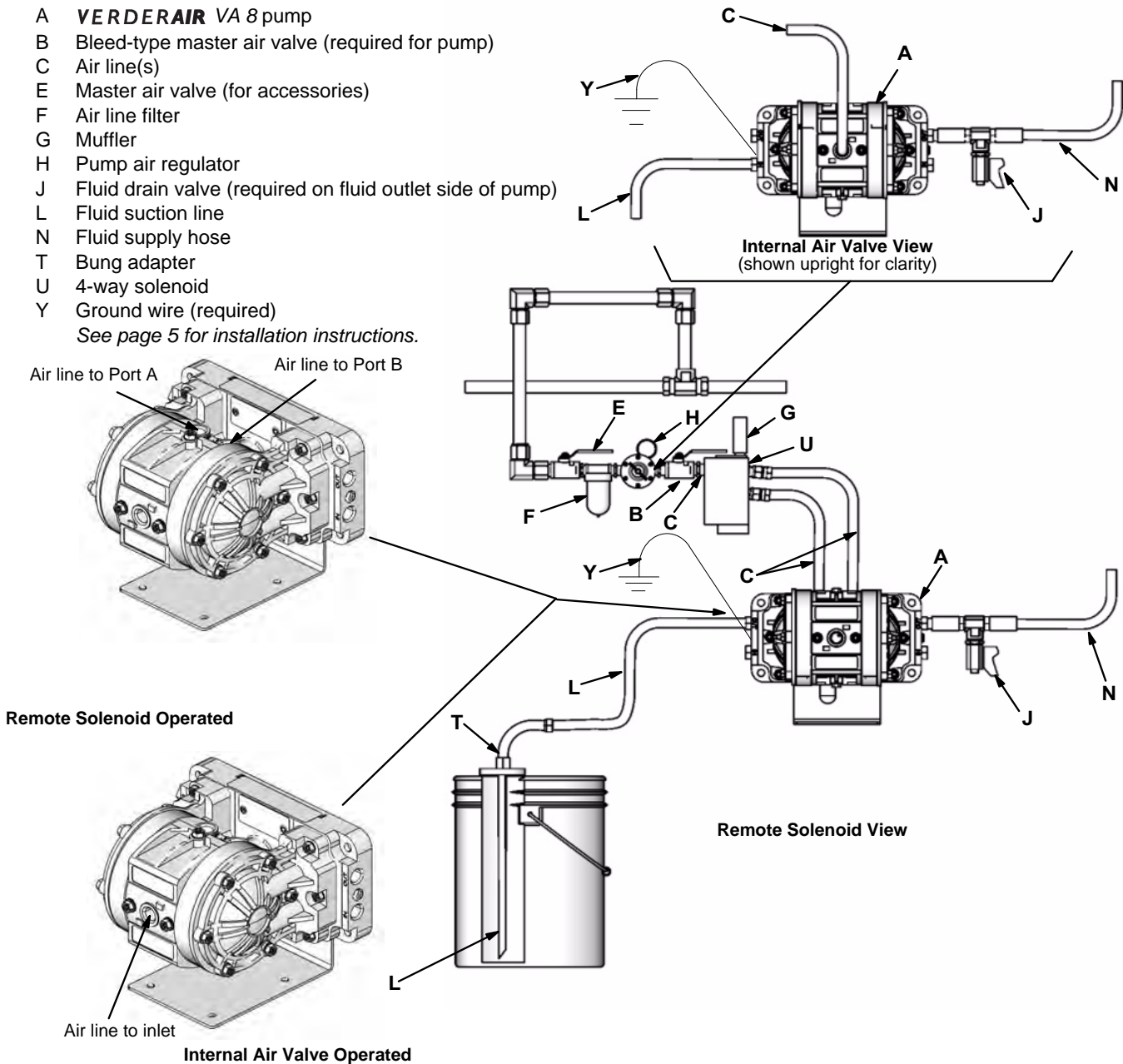

FIG. 4

ti10663a

VERDEAIR

Operation

Pressure Relief Procedure

Warning

To reduce the risk of serious injury, including splashing fluid in the eyes or on the skin, follow this procedure whenever you are instructed to relieve pressure, when you shut off the pump, and before you check, adjust, clean, move, or repair any system equipment.

1. Shut off air and reserve air to the pump.
2. Open the dispensing valve if the system has one.
3. Open the fluid drain valve to relieve all system pressure, and have a container ready to catch the drainage.

Flushing the Pump Before First Use

The pump was tested in water. If water could contaminate the fluid you are pumping, flush it thoroughly with a compatible solvent. Follow the procedure in **Starting and Adjusting the Pump**.

Starting and Adjusting the Pump

Warning

To reduce the risk of serious injury, splashing in the eyes or on the skin, and toxic fluid spills, **never** move or lift a pump under pressure. If the pump is dropped, the fluid section could rupture. Always follow the **Pressure Relief Procedure** above before you move or lift the pump.

1. Be sure the pump is properly grounded. Read and follow the instructions in **Grounding** on page 5.
2. Check all fittings to be sure they are tight. Be sure to use a compatible liquid thread sealant on all male threads. Tighten the fluid inlet and outlet fittings and plugs securely. Retorque all fasteners before start-up. See **Torque Sequence** on page 21.
3. Place the suction tube (if used) in the fluid to be pumped.
4. Place the end of the outlet hose into an appropriate container.
5. Close the fluid drain valve.
6. With the air regulator closed, open all bleed-type master air valves.

7. If the outlet hose has a dispensing device, hold it open while continuing with step 8.
8. Slowly open the air regulator until the pump starts to cycle. Allow the pump to cycle until all air is pushed out of the lines and the pump is primed.

NOTE: To prime a remote solenoid-operated air valve, operate the pump at a minimum 60 cpm rate until the pump is fully primed.

Pump Shutdown

At the end of the work shift, and before you check, adjust, clean, or repair the system, **relieve air and fluid pressure**.

Warning

To reduce the risk of serious injury whenever you are instructed to relieve pressure, always follow the **Pressure Relief Procedure** at left.

VERDERAIR

Maintenance

Lubrication

The air valve is lubricated at the factory and designed to operate without additional lubrication.

If added lubrication is desired, every 500 hours of operation (or monthly), remove the hose from the pump air inlet and add two drops of machine oil to the air inlet.

Caution

Do not over-lubricate the pump. Excess oil is exhausted through the muffler, which could contaminate your fluid supply or other equipment.

Tightening Threaded Connections

Before each use, check all hoses for wear or damage, and replace as necessary. Be sure all threaded connections are tight and free of leaks.

Check fasteners. Tighten or retorque as necessary. Although pump use varies, a general guideline is to retorque fasteners every two months. See **Torque Sequence** on page 21.

Flushing and Storage

Flush the pump to prevent the fluid from drying or freezing in the pump and damaging it. Always flush the pump and **relieve the pressure** before storing for any length of time. Use a compatible solvent.

Warning

To reduce the risk of serious injury whenever you are instructed to relieve pressure, always follow the **Pressure Relief Procedure** on page 9.

If you are flushing, run the pump long enough to thoroughly clean the pump and hoses, close the air regulator, and remove the suction hose from the solvent and place it in the fluid to be pumped.

If you are shutting down the pump, remove the suction hose from the fluid container, run the pump until the fluid is forced out of the system, and shut off the air supply immediately.

VERDERAIR

Troubleshooting

Relieve the pressure before you check or service the equipment.

Check all possible problems and causes before you disassemble the pump.

Warning

To reduce the risk of serious injury whenever you are instructed to relieve pressure, always follow the **Pressure Relief Procedure** on page 9.

Internal Air Valve-Operated and Remote Solenoid-Operated Pumps

PROBLEM	CAUSE	SOLUTION
The pump cycles at stall, or it fails to hold pressure at stall.	The check valves (20) or o-rings (21) are leaking.	Replace the check valves and/or o-rings. See page 16.
	The check valves (20) are worn.	Replace the check valves. See page 16.
	Debris is stuck between the a check valve (20) and the seat.	Clean the check valve/seat area. See page 16.
The pump operates erratically.	The suction line is clogged.	Inspect and clear the line.
	The check valves (20) are sticking or leaking.	Replace the check valves, or clean and check the valve/seat area. See page 16.
	A diaphragm (30) is ruptured.	Replace the ruptured diaphragm. See page 15.
There are air bubbles in the fluid.	The suction line is loose.	Tighten the suction line.
	A diaphragm (30) is ruptured.	Replace the ruptured diaphragm. See page 15.
	The manifold (52) is loose, or the o-rings (21) are damaged.	Tighten the manifold screws (58). Replace the o-rings (21). See page 16.
	The fluid covers (51) are loose.	Tighten the fluid cover screws (58). See page 15.
There is fluid in the exhaust air.	A diaphragm (30) is ruptured.	Replace the ruptured diaphragm. See page 15.
	A diaphragm plate (50) is loose.	Tighten the diaphragm plate. See page 15.
The pump exhausts air near the fluid covers.	The fluid covers (51) are loose, or the o-rings (57) are damaged.	Tighten the diaphragm plate. See page 15.
The pump exhausts air near the air valve.	The air valve cover screws (14) are loose.	Tighten the screws. See page 14.
	The top (5) and/or side (6) air valve o-rings are damaged.	Replace these o-rings. See the Parts Drawing on page 18.
The pump leaks fluid from the check valves.	The o-rings (21) are leaking, or the screws (58) are loose.	Replace these o-rings, and tighten the screws. See page 16.

VERDERAIR

Troubleshooting

Internal Air Valve-Operated Pumps Only

PROBLEM	CAUSE	SOLUTION
The pump will not cycle, or it cycles once and stops.	The air valve is stuck or dirty.	Disassemble and clean or repair the air. Use filtered air.
	Not enough air pressure supplied.	Increase air pressure supply. Do not exceed maximum input pressure.

Remote Solenoid-Operated Pumps Only

PROBLEM	CAUSE	SOLUTION
The pump will not prime or loses prime.	The cycle rate is too low.	Increase cycle rate to 60 cpm.
	The check valves (20) are not sealing.	Inspect the check valves, and replace them if worn or damaged. See page 16.
	Fluid manifold not mounted with OUT port up.	Re-mount fluid manifold so OUT port is up.
The pump leaks air or does not operate.	Air is supplied to Port A and Port B at the same time.	Replace both diaphragms (30). See page 15.
	Solenoid exhaust is plugged.	Check your installation. See page 8. Ensure that exhaust (G on page 8) is free of obstructions.

VERDERAIR Service

Service Kits

Service Kits may be ordered separately.

To repair the air valve, order Part No. 819.6249. Parts included in the Air Valve Service Kit are marked with an asterisk in the **Parts Drawing** on page 18, for example (3*).

For fluid section repair section parts, see the **Service Kit Listing** on page 17. Parts included in the Fluid Section Service Kit are marked with a dagger in the **Parts Drawing** on page 18, for example (4).

Servicing the Air Valve

Service the air valve as follows. See FIG. 5.

1. **Relieve the fluid pressure**, and disconnect air line from the pump.

Warning

To reduce the risk of serious injury whenever you are instructed to relieve pressure, always follow the **Pressure Relief Procedure** on page 9.

2. Remove the four screws (14) that hold the valve cover (7) on the center housing (1).
3. Remove the valve block (4) and valve carriage (2), and replace the u-cups (3). Replace the valve carriage and valve block. When you replace the valve carriage, position it all the way to one side or the other.

NOTE: The valve block shown in FIG. 5 is for pumps with an air-operated air motor. If your pump has a solenoid-operated air motor, this step does not pertain. Items 2, 3, 4, 16, and 17 are not required.

4. Clean any parts that are dirty.
5. To reinstall the valve cover (7), spread cover apart enough not to damage the square ring packings (6) and slide cover (7) into the center section.
6. Install the screws (14), and torque to 45–47 in-lb (5.0–5.3 Nm). See **Torque Sequence** on page 21.
7. Reconnect the pump.

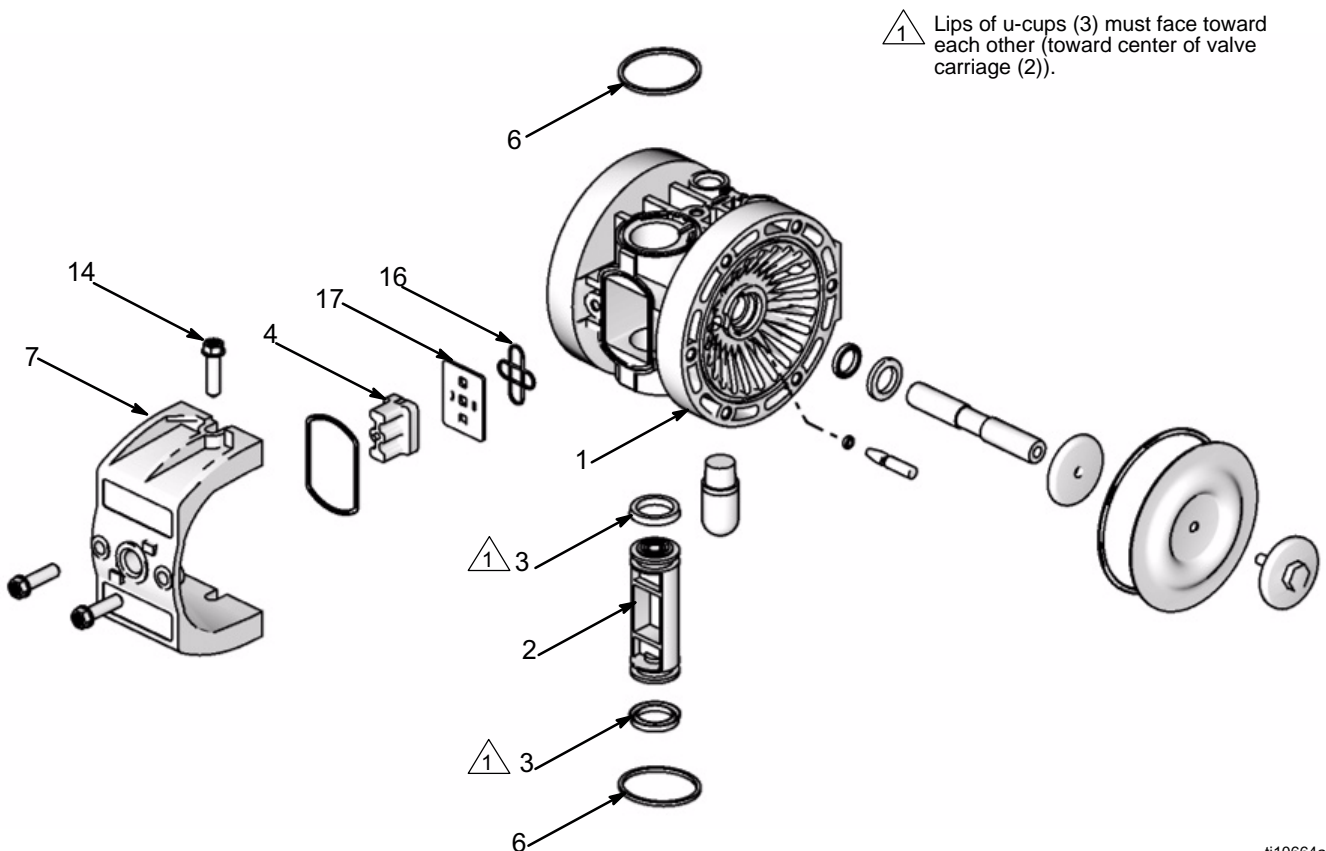

FIG. 5
14 819.6247

VERDERAIR

Service

Replacing Diaphragms

Replace the diaphragms as follows. See FIG. 6 and FIG. 7.

1. **Relieve the pressure**, and disconnect the air line from the pump.

Warning

To reduce the risk of serious injury whenever you are instructed to relieve pressure, always follow the **Pressure Relief Procedure** on page 9.

2. Remove the eight screws (58) that fasten the two fluid covers (51) to manifold (52), and remove the fluid cover/center housing assembly from the manifold.
3. Remove the six screws (58) that fasten each fluid cover (51) to the center housing (1), and pull the fluid covers off of the center housing.
4. Remove the diaphragm plates (50) from the shaft (10), and remove the diaphragms (30), and air-side diaphragm plates (11).
5. Remove the diaphragm pins (8), remove and replace the o-rings (9), and reinstall the diaphragm pins in the center housing (1).
6. Reinstall the diaphragm shaft (10).
7. Install the new diaphragms (30) with the concave side toward the center housing (1).
8. Screw the diaphragm plates (50) onto the shaft (10), and torque to 40 in-lb (4.5 Nm)
9. Reinstall the fluid covers (51) on the center housing (1), install the screws (58) that fasten the fluid covers to the center housing, and torque to 42–47 in-lb (4.7–5.3 Nm). See **Torque Sequence** on page 21.
10. Reinstall the fluid covers/center housing assembly on the manifold (52), install the screws (58) that fasten the fluid covers/center housing assembly to the manifold, and torque to 42–47 in-lb (4.7–5.3 Nm). See **Torque Sequence** on page 21.
11. Reconnect the pump.

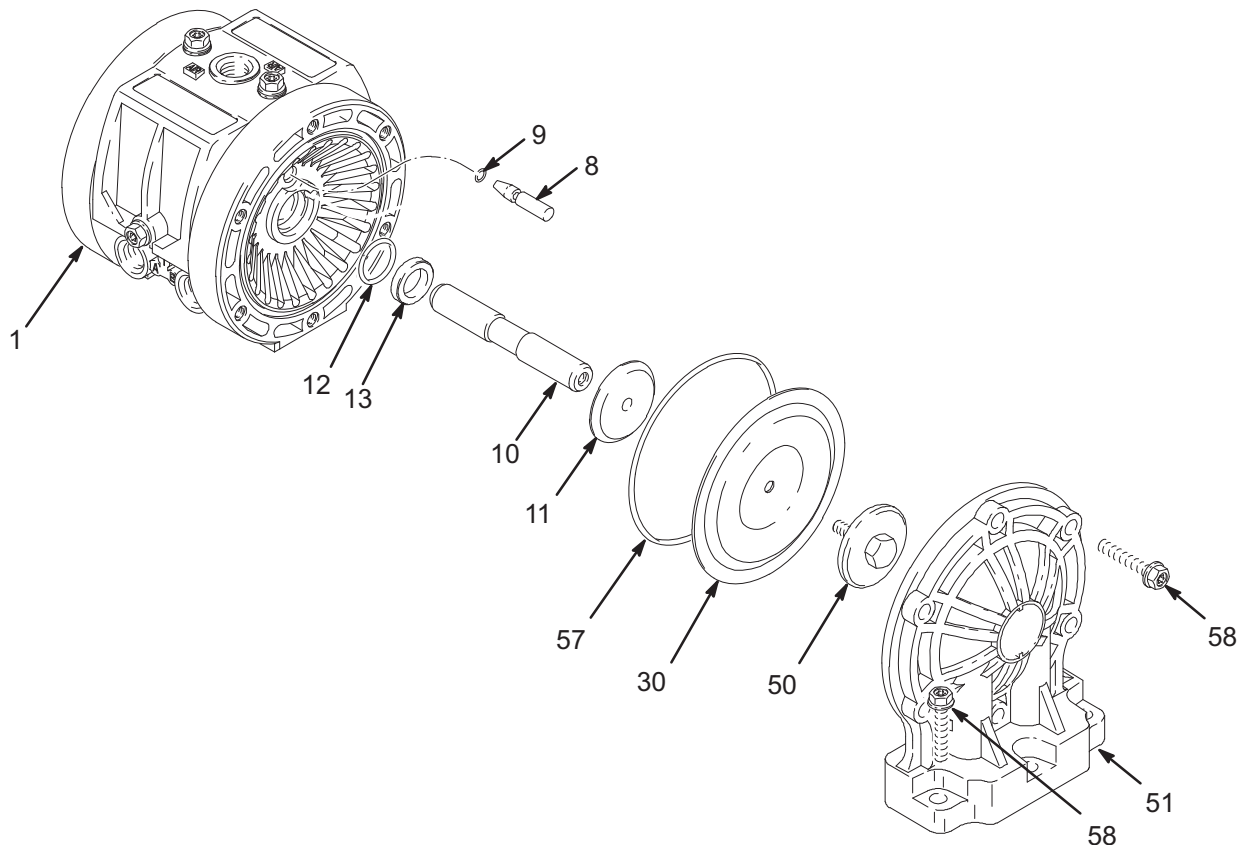

FIG. 6

06180c

VERDERAIR

Service

Replacing Check Valves

Replace each pair of check valves as follows. See FIG. 7.

1. **Relieve the pressure**, and disconnect the air line from the pump.

Warning

To reduce the risk of serious injury whenever you are instructed to relieve pressure, always follow the **Pressure Relief Procedure** on page 9.

2. Remove the eight screws (58) that hold the fluid cover/center housing assembly on the manifold (52), and lift the manifold covers/center housing assembly off of the manifold (52).
3. Remove and replace the check valves (20), **being careful** to orient each check valve exactly like the one it **is replacing**. Make sure the check valve/seat area is clean.
4. Remove and replace the sealing o-rings (21). Once compressed, o-rings may not be reused. Make sure the check valve/seat area is clean.
5. Reinstall the fluid covers/center housing assembly on the manifold (52), install the screws (58) that fasten the fluid covers/center housing assembly to the manifold, and torque to 42–47 in-lb (4.7–5.3 Nm). See **Torque Sequence** on page 21.
6. Reconnect the pump.

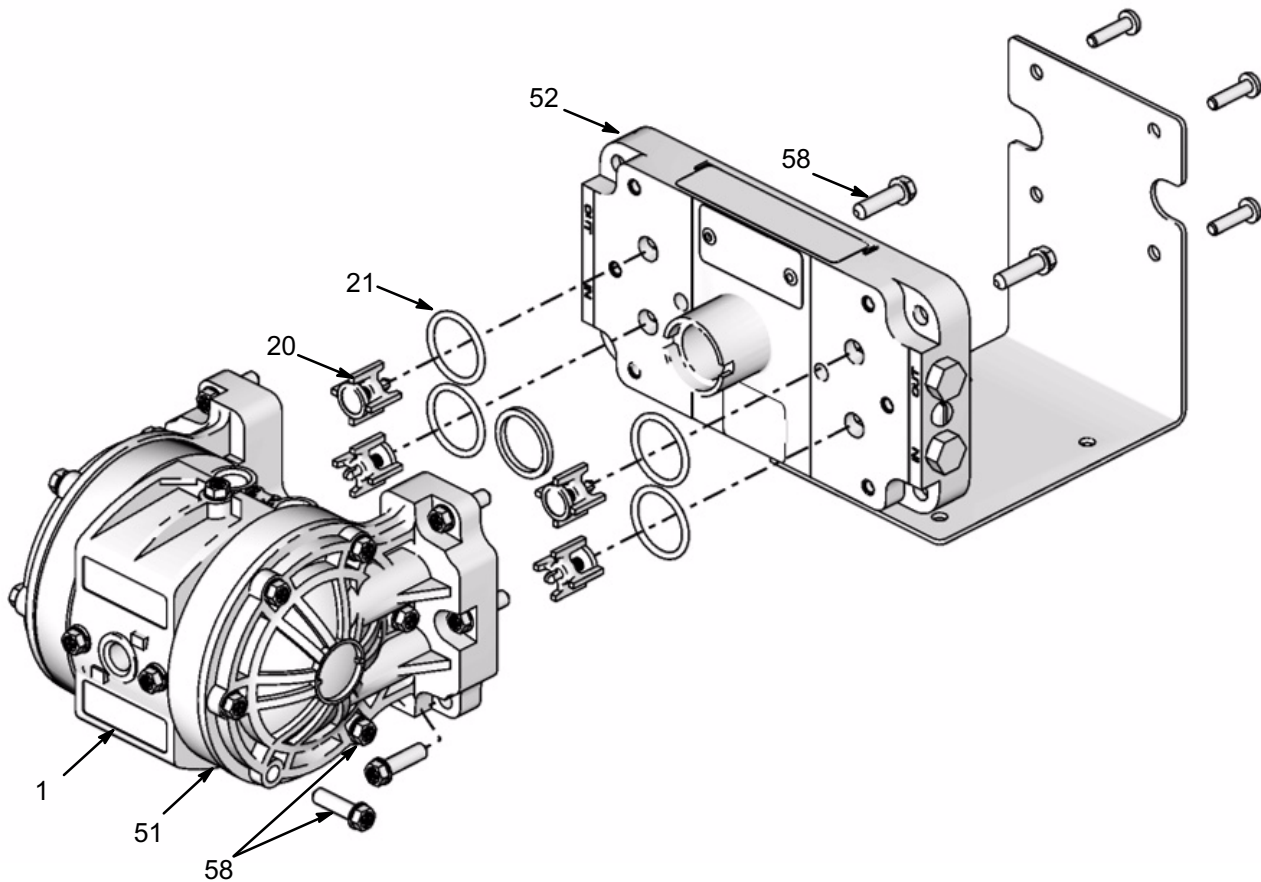

FIG. 7

ti10665a

VERDERAIR

Service Kit Listing

Air Valve and Fluid Section Service Kits for VERDERAIR VA 8 Pumps

Valve seats, check balls, and diaphragms may only be ordered as kits. Parts included in the kits are marked with a symbol in the parts list, for example (2†). The list of Fluid Service Kits is below:

Kit	Air Motor	Seats	Checks	Diaphragms	Seals
819.1314	ALL	—	KY	SP	VT/TF
819.6025	ALL	—	AC	SP	VT/TF
819.6026	ALL	—	—	SP	VT/TF
819.6027	ALL	—	—	—	VT/TF
819.6028	ALL	—	—	TF	VT/TF
819.6029	ALL	—	AC	—	VT/TF
819.6030	ALL	—	AC	TF	VT/TF
819.6031	ALL	—	PP	—	VT/TF
819.6032	ALL	—	PP	TF	VT/TF
819.6033	ALL	—	KY	—	VT/TF
819.6034	ALL	—	KY	TF	VT/TF
819.7095	ALL	—	PP	SP	VT/TF

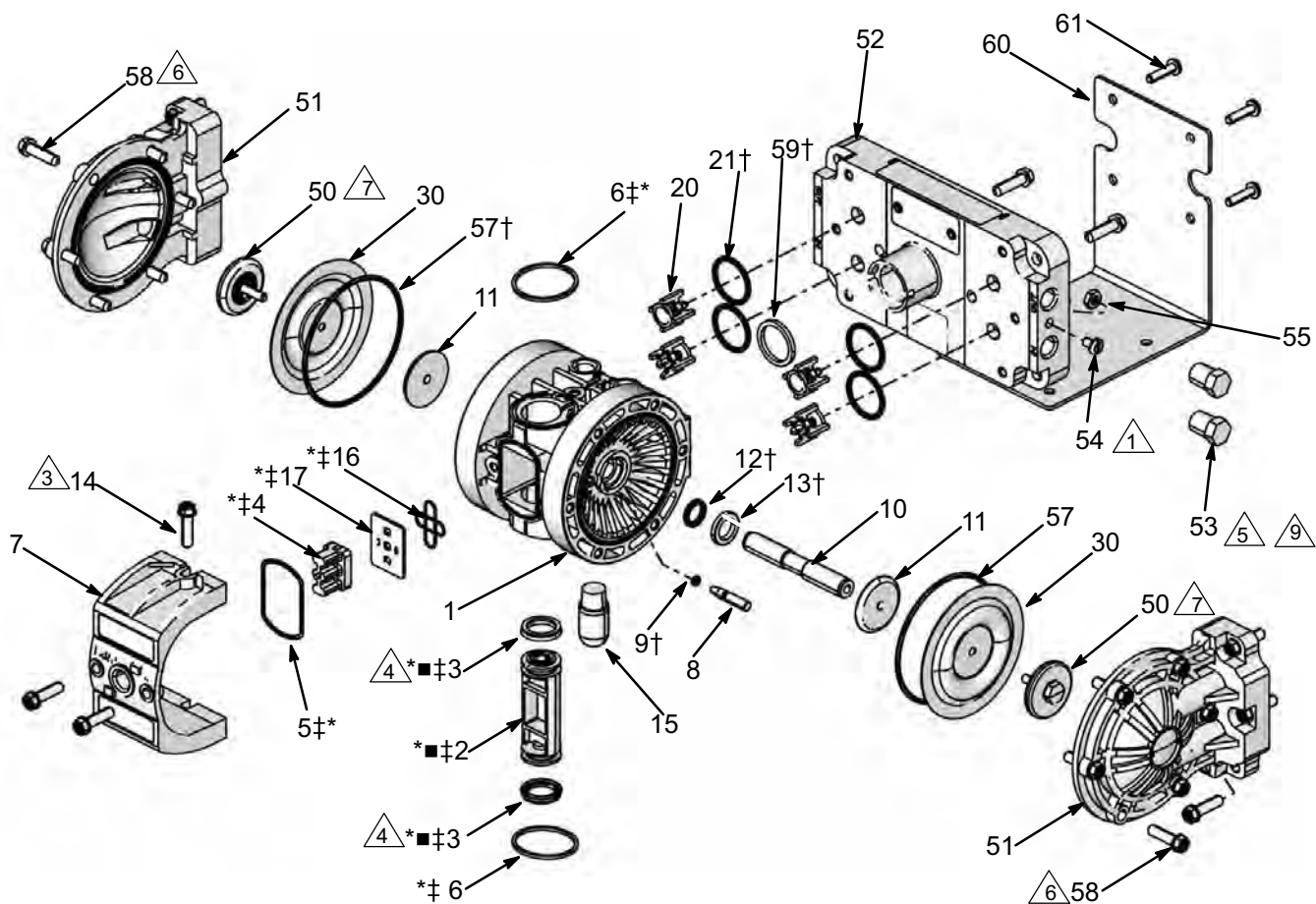

ti10666

△ 1 Used on acetal models only.

△ 3 Torque to 45–47 in-lb (5.0–5.3 N•m). See **Torque Sequence** on page 21.

△ 4 Lips of u-cups (3) must face toward each other, toward center of valve carriage (2).

△ 5 Torque to 20 in-lb (2.2 N•m).

△ 6 Torque to 42–47 in-lb (4.7–5.3 N•m). See **Torque Sequence** on page 21.

△ 7 Torque to 28–33 in-lb (3.2–3.7 N•m). See **Torque Sequence** on page 21.

△ 9 Not assembled. These plugs are supplied to plug the two ports in the manifold that are not used.

■ These parts cannot be ordered separately. They come preassembled and are included as part of the Air Valve Service Kit 819.6249.

* These parts are included in Air Valve Service Kit 819.6249, which may be purchased separately.

† These parts are included in Fluid Section Service Kit. See page 17 to find the correct kit for your pump.

‡ These parts are included in pump with integral air valve only.

Parts

Air Motor Section

Option (Code 9)	Ref. No.	Part No.	Description	Qty.
00	1	819.0069	HOUSING, center	1
	2	819.6252	CARRIAGE, valve	1
	3	819.6860	SEAL, u-cup	2
	4	819.6901	VALVE BLOCK (for pump with air-operated air motor)	1
	5	819.6256	GASKET, molded	1
	6	819.7016	Packing, square ring	2
	8	819.6258	PIN, actuator	2
	9	819.6259	O-RING, packing	2
	10	819.6902	SHAFT, diaphragm	1
	11	819.7017	PLATE, diaphragm, air side	2
	12	819.7018	O-RING, diaphragm shaft	2
	13	819.9760	BEARING, retaining	2
	14	819.6263	SCREW, torx	4
	15	819.6861	MUFFLER, porous plastic	1
	16	819.6904	SEAL, valve plate	1
	17	819.6905	PLATE, valve	1
	RE	1	819.6906	HOUSING, center
10		819.6902	SHAFT, diaphragm	1
11		819.7017	PLATE, diaphragm, air side	1
12		819.7018	O-RING, diaphragm shaft	2
13		819.9760	BEARING, retaining	2
14		819.6263	SCREW, torx	4
15		819.6861	MUFFLER, porous plastic	1
16		819.6904	SEAL, valve plate	1
17		819.6905	PLATE, valve	1

Fluid Section

Fluid Section Material (Code 3)	Ref. No.	Part No.	Description	Qty.	
D	7	819.5965	COVER, valve	1	
	49	819.6313	LABEL, warning	1	
	50	819.6271	PLATE, diaphragm; acetal	2	
	51	819.7019	COVER, fluid; acetal	2	
	52	819.0316	MANIFOLD; acetal	1	
	53	819.6272	PLUG, port; acetal	2	
	54	819.0186	SCREW, grounding	2	
	55	819.0185	NUT, hex, grounding	2	
	57	819.6273	O-RING, packing	2	
	58	819.6263	SCREW, torx	20	
	59*	819.7021	O-RING, exhaust Series D	1	
		819.0289	Series C, E		
	60	819.6908	BRACKET, mounting	1	
	61	819.0175	SCREW, machine, pn hd	4	
	P	7	819.5965	COVER, valve	1
		49	819.6313	LABEL, warning	1
		50	819.6274	PLATE, diaphragm; polypropylene	2
51*		819.7022	COVER, fluid; polypropylene Series C	2	
		819.1340	Series D pumps with date codes before September 11, 2019. Series D pumps with date codes on or after September 11, 2019. Series E		
52*		819.0315	MANIFOLD; polypropylene Series D	1	
		819.7023	Series C, E		
53		819.6265	PLUG, port; polypropylene	2	
57		819.6273	O-RING, packing	2	
58		819.6263	SCREW, torx	20	
59		819.0289	O-RING, exhaust	1	
60		819.6908	BRACKET, mounting	1	
61		819.0175	SCREW, machine, pn hd	4	

VERDEAIR

Fluid Section Material (Code 3)	Ref. No.	Part No.	Description	Qty.
K	7	819.5965	COVER, valve	1
	49	819.6313	LABEL, warning	1
	50	819.6275	PLATE, diaphragm; PVDF	2
	51	819.7024	COVER, fluid; PVDF	2
	52	819.0317	MANIFOLD; PVDF	1
	53	819.6276	PLUG, port; PVDF	2
	57	819.6273	O-RING, packing	2
	58	819.6263	SCREW, torx	20
	59	819.0289	O-RING, exhaust	1
	60	819.6908	BRACKET, mounting	1
	61	819.0175	SCREW, machine, pn hd	4

Check Valve Kits

Check Valve Material (Code 6)	Ref. No.	Part No.	Description	Qty.
AC	20	819.6029	VA08P --,AC,--,VT/TF	1
	21	Included in above kit		
PP	20	819.6031	VA08P --,PP,--,VT/TF	1
	21	Included in above kit, thinner cross-section seals	Series C Series D pumps with date codes before September 11, 2019.	
	21	Included in above kit, thicker cross-section seals	Series D pumps with date codes on or after September 11, 2019. Series E	
KY	20	819.6033	VA08P --,KY,--,VT/TF	1
	21	Included in above kit		

Diaphragm Kits

Diaphragm Material	Ref. No.	Part No.	Description	Qty.
TF	30	819.6028	VA08P --,--,TF,VT/TF	1
SP	30	819.6026	VA08P --,--,SP,VT/TF	1

VERDERAIR

Torque Sequence

For proper installation, always follow torque sequence whenever you are instructed to torque screws.

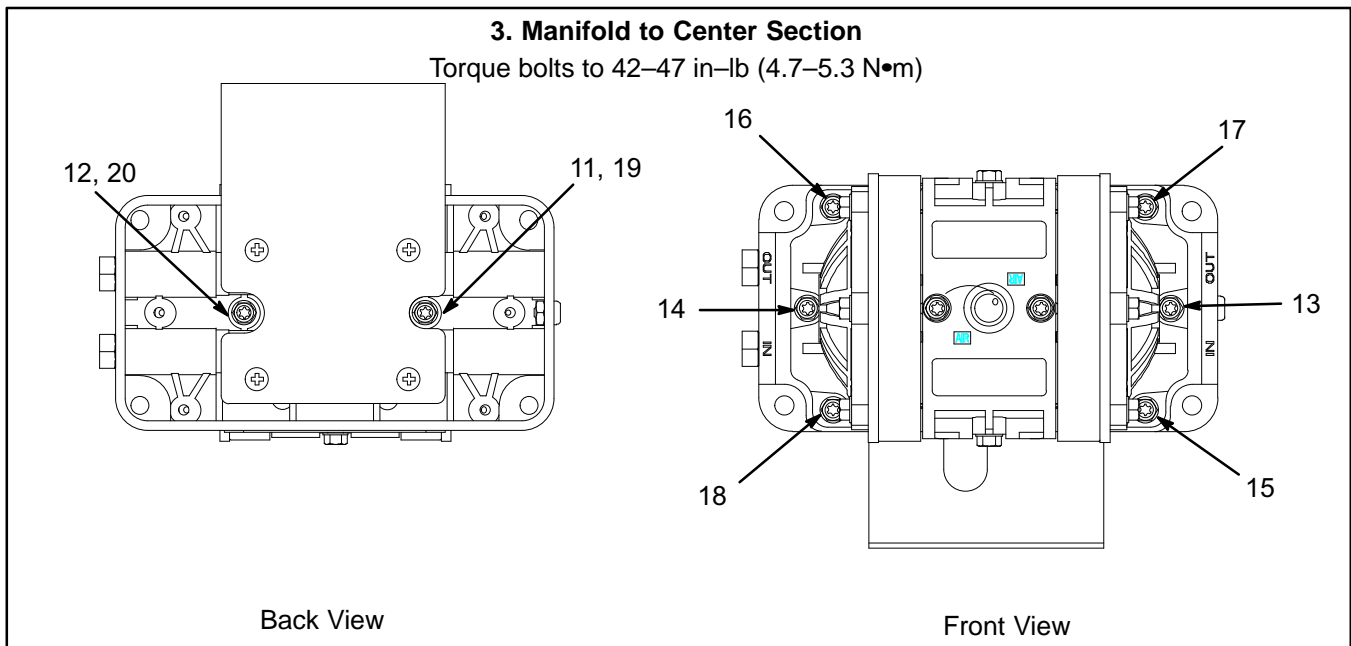
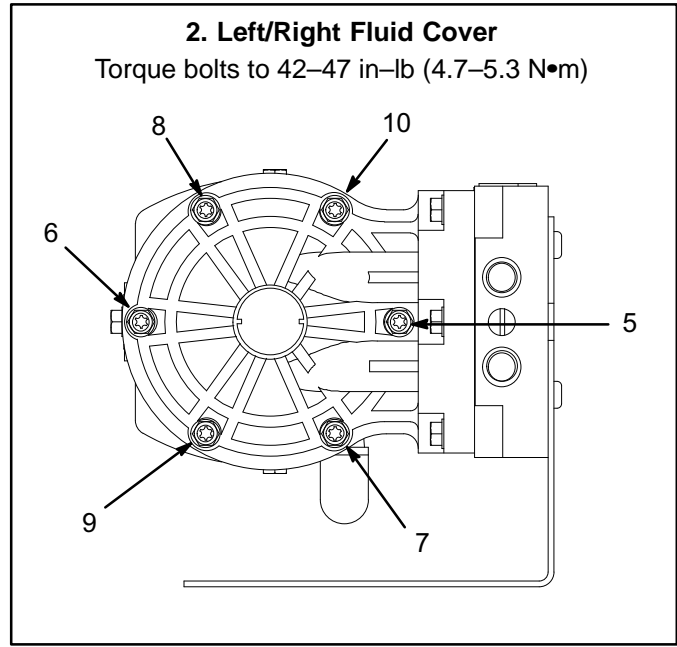
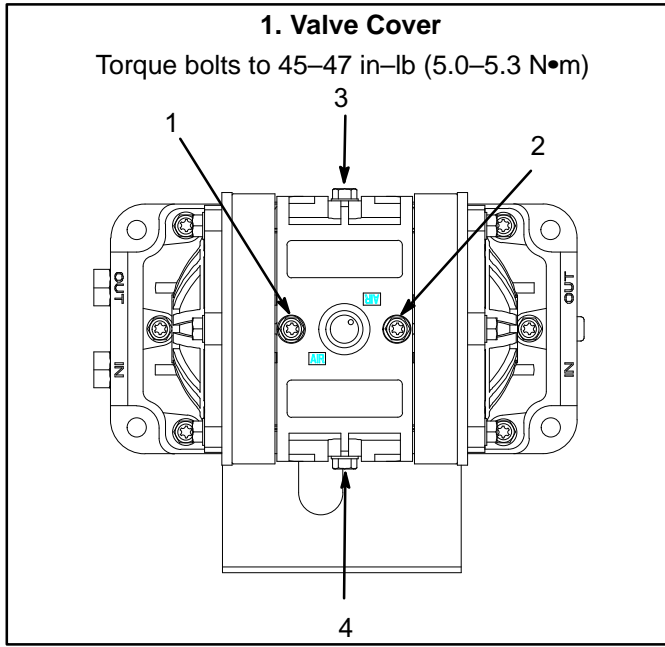

VERDERAIR

Technical Data

Maximum fluid working pressure	100 psi
	0.7 MPa (7 bar)
Maximum/minimum air pressure	100 psi/20 psit
	0.7 MPa (7 bar)
	0.14MPa (1.4 bar)
Maximum fluid flow	5 gpm (18,9 lpm)
Maximum pump speed.....	320(dry) cycles per minute
	250(wet) cycles per minute
Volume per stroke*	0.006 gal (23 cc)
Volume per cycle*	0.0012 gal (46 cc)
Maximum suction lift dry	8 to 10 foot
	(2,5 to 3 m)
Maximum size pumpable solids	0.06 in (1,5 mm)
Maximum operating temperature	180 F (82 C)
Maximum air consumption	9.0 scfm
	0,252 m ³ /min.
Air inlet size**	1/4 npt(f)/1/4 bspt(f)
Fluid inlet size**	1/4 npt(f)/1/4 bspt(f)
Fluid outlet size**	1/4 npt(f)/1/4 bspt(f)
Air exhaust port size**	1/4 npt(f)/1/4 bspt(f)

Weight

Polypropylene pump	2.0 lb (0.9 kg)
Acetal pump	2.5 lb (1,1 kg)
PVDF pump.....	2.8 lb (1.3 kg)

Wetted parts (housings, diaphragms, check valves)

Polypropylene pump:
Glass-filled polypropylene, PTFE, polypropylene, hastelloy

Acetal pump:
Acetal with SST fibers, PTFE, acetal, hastelloy

PVDF pump:
PVDF, PTFE, PVDF, hastelloy

Sound power level (pressure) (per ANSI STD S12.1)

at 100 psi (0.7 MPa, 7 bar).....	75.5 dBa
at 70 psi (0.49 MPa, 4.9 bar).....	72.0 dBa
at 40 psi (0.28 MPa, 2.8 bar).....	68.2 dBa

Sound power level (intensity) (per ANSI STD S12.1)

at 100 psi (0.7 MPa, 7 bar).....	84.5 dBa
at 70 psi (0.49 MPa, 4.9 bar).....	81.1 dBa
at 40 psi (0.28 MPa, 2.8 bar).....	76.6 dBa

† Minimum startup pressure may vary based on environmental conditions.

* Volume per cycle may vary based on suction condition, discharge head, air pressure, and fluid.

** Hybrid thread allows for either 1/4 npt or 1/4 bspt fitting.

Santoprene is a registered trademark of the Monsanto Company.

Dimensions and Mounting Hole Layout

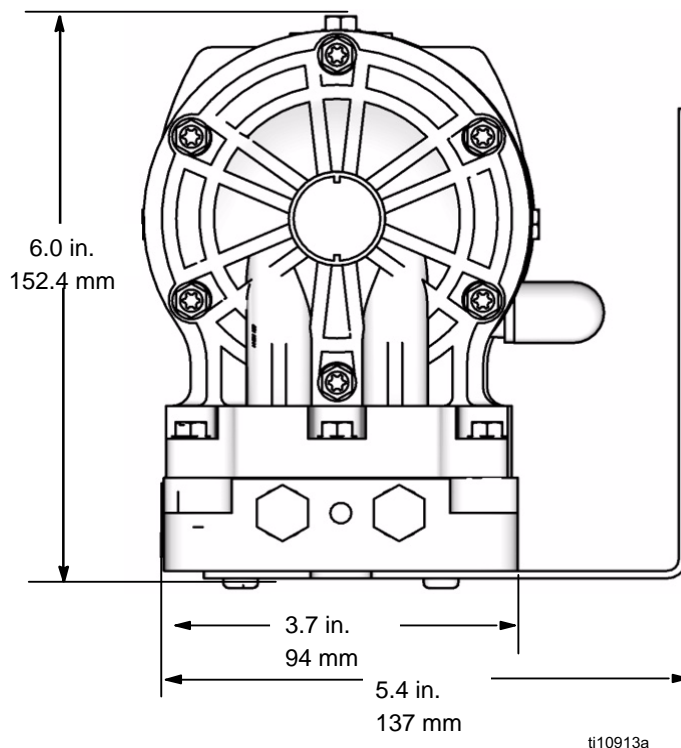

Four 0.230 in.
(5.8 mm)
diameter holes

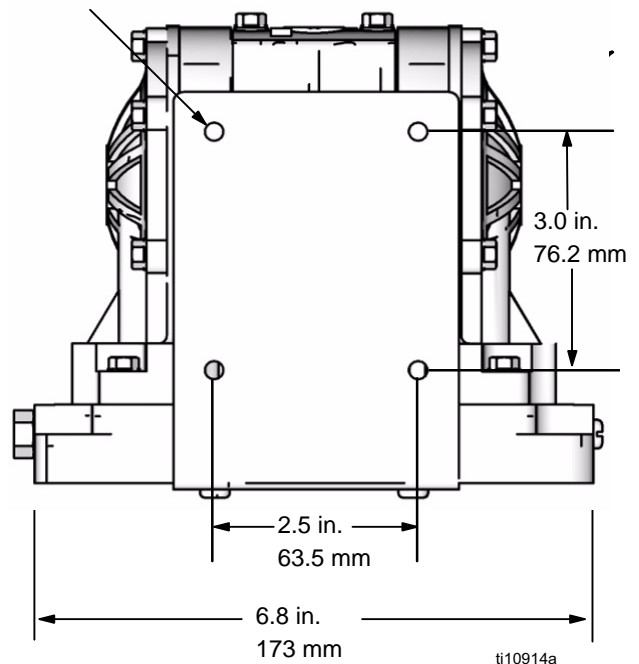

VERDERAIR

Performance Charts

VERDERAIR VA 8 Fluid Outlet Pressure

Test Conditions: Pump tested in water with inlet submerged.

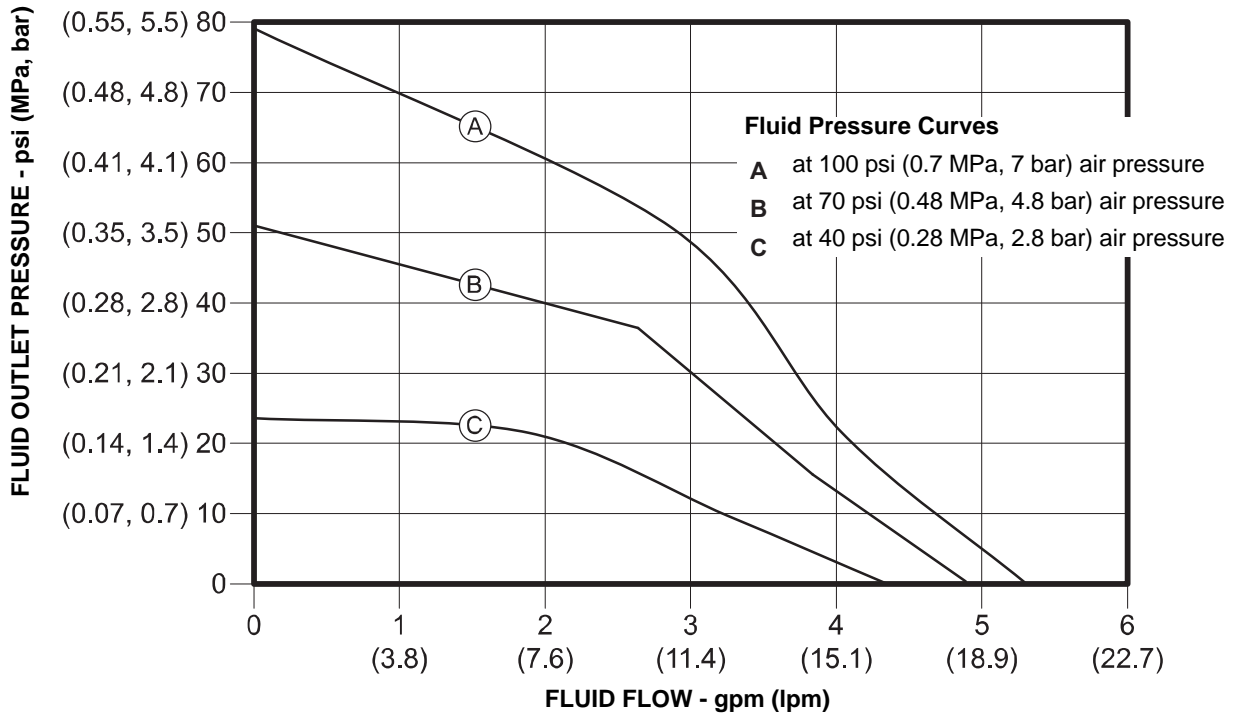

To find Fluid Outlet Pressure (psi/MPa/bar) at a specific fluid flow (gpm/lpm) and operating air pressure (psi/MPa/bar):

1. Locate fluid flow rate along bottom of chart.
2. Follow vertical line up to intersection with selected fluid outlet pressure curve.
3. Follow left to scale to read fluid outlet pressure.

VERDERAIR

Performance Charts

VERDERAIR VA 8 Air Consumption

Test Conditions: Pump tested in water with inlet submerged.

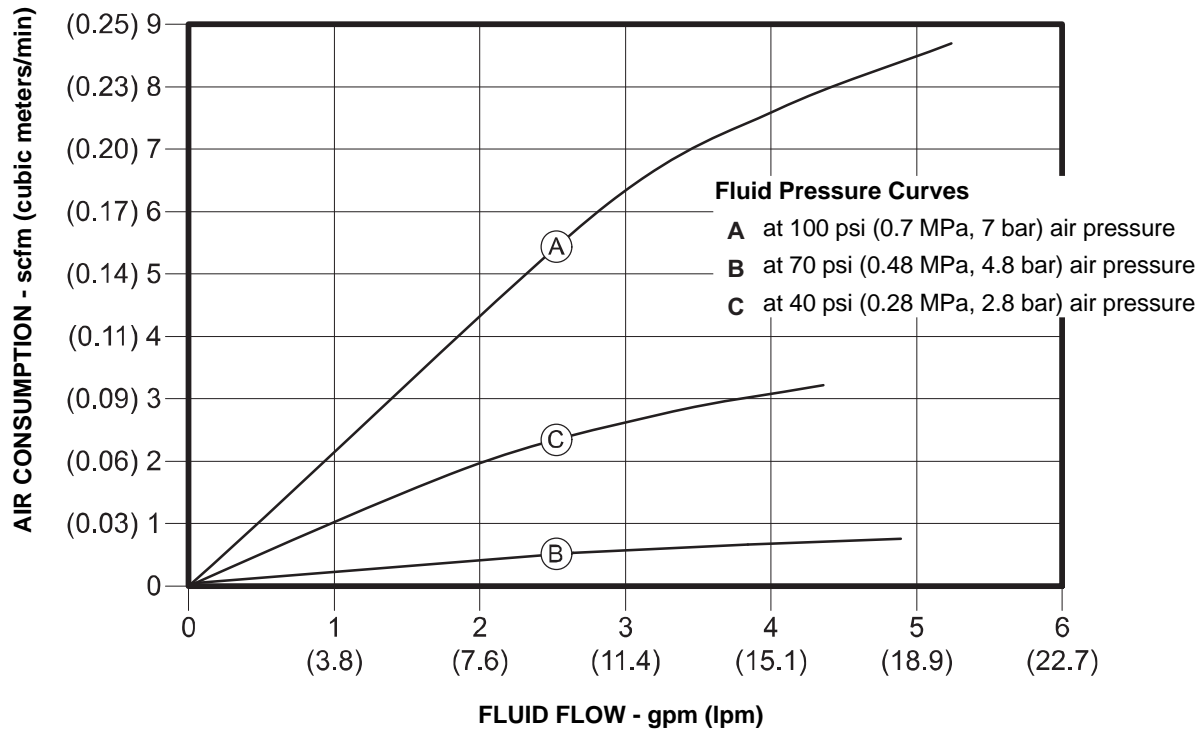

To find Pump Air Consumption (scfm or m³/min) at a specific fluid flow (gpm/lpm) and air pressure (psi/MPa/bar):

1. Locate fluid flow rate along bottom of chart.
2. Read vertical line up to intersection with selected air consumption curve.
3. Follow left to scale to read air consumption.

VERDERAIR

Customer Services/Guarantee

CUSTOMER SERVICES

If you require spare parts, please contact your local distributor, providing the following details:

- Pump Model
- Type
- Serial Number, and
- Date of First Order.

GUARANTEE

All VERDER pumps are warranted to the original user against defects in workmanship or materials under normal use (rental use excluded) for two years after purchase date. This warranty does not cover failure of parts or components due to normal wear, damage or failure which in the judgement of VERDER arises from misuse.

Parts determined by VERDER to be defective in material or workmanship will be repaired or replaced.

LIMITATION OF LIABILITY

To the extent allowable under applicable law, VERDER's liability for consequential damages is expressly disclaimed. VERDER's liability in all events is limited and shall not exceed the purchase price.

WARRANTY DISCLAIMER

VERDER has made an effort to illustrate and describe the products in the enclosed brochure accurately; however, such illustrations and descriptions are for the sole purpose of identification and do not express or imply a warranty that the products are merchantable, or fit for a particular purpose, or that the products will necessarily conform to the illustration or descriptions.

PRODUCT SUITABILITY

Many regions, states and localities have codes and regulations governing the sale, construction, installation and/or use of products for certain purposes, which may vary from those in neighboring areas. While VERDER attempts to assure that its products comply with such codes, it cannot guarantee compliance, and cannot be responsible for how the product is installed or used.

Before purchasing and using a product, please review the product application as well as the national and local codes and regulations, and be sure that product, installation, and use complies with them.

Austria

Verder Austria
Eitnergasse 21/Top 8
A-1230 Wien
AUSTRIA
Tel: +43 1 86 51 074 0
Fax: +43 1 86 51 076
e-mail: office@verder.at

Belgium

Verder nv
Kontichsesteenweg 17
B-2630 Aartselaar
BELGIUM
Tel: +32 3 877 11 12
Fax: +32 3 877 05 75
e-mail: info@verder.be

China

Verder Shanghai Instruments and Equipment Co., Ltd
Building 8 Fuhai Business Park No. 299
Bisheng Road, Zhangjiang Hiteck Park
Shanghai 201204
CHINA
Tel: +86 21 33932950
Fax: +86 21 33932955
e-mail: info@verder.cn

Bulgaria

Verder Bulgaria Ltd
Vitosh department,
Manastriski Livadi Zapad
district,
110 Bulgaria Blvd., 2-nd
Floor, apt. 15-16,
1618 - Sofia
BULGARIA
Tel: 0878407370
Fax: 02 9584085
email: office@verder.bg

Czech Republic

Verder s.r.o.
Vodnanská 651/6 (vchod
Chlumecka 15)
198 00 Praha 9-Kyje
CZECH REPUBLIC
Tel: +420 261 225 386-7
Web: <http://www.verder.cz>
e-mail: info@verder.cz

France

Verder France
8 Allée Rosa Luxembourg
Immeulde Arizona
95610 Eragny sur Oise
FRANCE
Tel: +33 173 43 98 41
Fax: +33 134 64 44 50
e-mail: info@verder.fr

Germany

Verder Deutschland GmbH
Retsch-Allee 1-5
42781 Haan
GERMANY
Tel: 02104/2333-200
Fax: 02104/2333-299
e-mail: info@verder.de

Hungary

Verder Hungary Kft
Budafoke ut 187 - 189
HU-1117 Budapest
HUNGARY
Tel: 0036 1 3651140
Fax: 0036 1 3725232
e-mail: info@verder.hu

India

Verder India Pumps Pvt
Ltd.
Plot No-3B, D-1 Block,
MIDC Chinchwad,
Pune - 411019
INDIA
e-mail:
Sales@verder.co.in
www.verder.co.in

Italy

Verder Italia
Via Maestri Del lavoro, 5
02100 Vazia, Rieti
ITALY
Tel: +39 07 46 229064
e-mail: info@verder.it

The Netherlands

Verder BV
Leningradweg 5
NL 9723 TP Groningen
THE NETHERLANDS
Tel: +31 50 549 59 00
Fax: +31 50 549 59 01
e-mail: info@verder.nl

Poland

Verder Polska
ul.Porcelanowa 23
PL-40 036 Katowice
POLAND
Tel: +48 32 78 15 032
Fax: +48 32 78 15 034
e-mail: verder@verder.pl

Romania

Verder România
Drumul Balta Doamnei
no 57-61
Sector 3
CP 72-117
032624 Bucuresti
ROMANIA
Tel: +40 21 335 45 92
Fax: +40 21 337 33 92
e-mail: office@verder.ro

Slovak Republik

Verder Slovakia s.r.o.
Silacska 1
SK-831 02 Bratislava
SLOVAK REPUBLIK
Tel: +421 2 4463 07 88
Fax: +421 2 4445 65 78
e-mail: info@verder.sk

South Africa

Verder SA
197 Flaming Rock Avenue
Northlands Business Park
Newmarket Street
ZA Northriding
SOUTH AFRICA
Tel: +27 11 704 7500
Fax: +27 11 704 7515
e-mail: info@verder.co.za

Switzerland

Verder Deutschland GmbH
Sales Switzerland
Retsch-Allee 1-5
D-42781 Haan
GERMANY
Tel: +41 (0)61 331 33 13
Fax: +41 (0)61 331 63 22
e-mail: info@verder.ch

United Kingdom

Verder UK Ltd.
Unit 3 California Drive
Castleford, WF10 5QH
UNITED KINGDOM
Tel: +44 (0) 1924 221 001
Fax: +44 (0) 1132 465 649
e-mail: info@verder.co.uk

United States of America

Verder Inc.
312 Corporate Parkway
Suite 101
Macon, GA 31210
USA
Tel: +1 877 783 7337
Fax: +1 478 476 9867
e-mail: sales@verder-us.com